

## **WARRANTY**

We warrant that the equipment built by us will be free from defects of material or workmanship and, if properly used, will do the work for which it is designed.

Any Part or parts which, upon our examination, are found to be defective will be replaced or repaired, at our option. Said part or parts must be returned, freight prepaid, to the home plant. The repaired part or parts will be shipped F.O.B. Minneapolis, Minnesota.

This is an unqualified warranty to the original purchaser of the equipment and shall apply for the period of one year from the date of shipment of the equipment from our plant.



# INDEX

Precautions for the Installation and Operation of Pneumatic Die Cushions .....	2
Types of Mountings .....	3
<b>Installation Instructions</b>	
Model HC Bolster Plate Mounting .....	5
Model HC Press Bed Mounting .....	8
Instructions for Installing Multiple Cushions Installations.....	10
<b>Parts List and Accessories</b>	
Cushion Surge Size.....	12
Combination Reducing Regulating Valve and Pressure Gauge .....	13
Pressure Gauge .....	14
Surge Tanks.....	16
Lubrication.....	17
Pneumatic Packings.....	21
Pneumatic Booster Pump.....	24
Model HC Parts List .....	28
Tonnage and Ring Holding Force Necessary For Drawing Shells .....	30
Tonnage Capacities On Presses.....	33
Die Cushions Lubricant .....	34
High Pressure Cushion Pipng Layout.....	35
Multiple High Pressure Cushions Pipng Layout .....	36



**LOOK FOR THIS SYMBOL TO POINT OUT IMPORTANT SAFETY PRECAUTIONS. IT MEANS – ATTENTION! BECOME ALERT! YOUR SAFETY IS INVOLVED.**

## **Precautions for the Installation and Operation of Pneumatic Die Cushions**

In order to get efficient and trouble free performance on any pneumatic die cushion installation, it is very important that the pin pressure pad or wear plate of the die cushion unit be parallel with the top of the press had and adjusted to its correct height relative to the top of the press bed. The maximum amount that the pin pressure pad can be out of parallel with the top of the press bed and still work satisfactorily is 1/64". For this reason it is important that the mounting rods on both the bolster plate mounting and the press bad mounting be checked periodically to make sure all the nuts are tight and that the adjustment at all four corners is uniform. If this adjustment is not maintained, the cylinder will not travel parallel to the piston and as a result cause breakdown of the cushion cylinder.



When a piece of work jams in a drawing or forming die, do not remove the jammed part by using the die cushion with the air pressure on. The air pressure should be turned off and system air drained before attempting to remove jammed part from the die. When a part is removed with the air pressure on, a severe shock is caused against the stop and adjusting nut on the Model D and MD or on the stop rods on the Model C, HC or HD cushion, which may cause a breakdown of the cushion unit. In addition to this it is very dangerous from the operator's standpoint, as the part sometimes comes loose with much force it may cause personal injury.

It should be remembered that once a pneumatic die cushion has been inflated to the required pressure, it theoretically uses no more air. The combination reducing regulating valve merely maintains the required pressure, by compensating for any air leaks through the pipe connections, packings or fittings.

If an air leak develops in the cushion unit, it is generally assumed that the packings are worn out and must be replaced. However, if the cushion has not been used for a period of two or three weeks it is advisable to inject two or three shots of grease into each grease fitting to soften the packing. Also, under severe vibration conditions the metal tubing may fracture near the connections and cause an air leak which may be mistaken for a leaking cap packing. Before disassembling C and D cushions it is advisable to check these fittings as explained on page 17.



Note: Pneumatic Die Cushions should always be loaded evenly. When die requires pins to be unbalanced, use **compensating pins** to balance load, Dayton Die Cushions manufactures cushions specifically designed to customers' requirements for jobs where off-center loading is necessary.



**CAUTION!** Failure to lubricate as instructed may result in permanent mechanical damage to internal working parts of die cushion or counterbalance cylinder. This may result in seizure of unit and **possibility of injury** to operating personnel.

## Types of Mountings

Dayton Pneumatic Die Cushions are designed and constructed primarily for deep drawing die operations; however, they can be used to an advantage for pressure pad control on forming dies as well as for stripper pad control on compound blanking and piercing dies. To meet these requirements several different die cushion models were developed which could be suspended from the **bolster plate** of the press or directly from the **press bed**.

### BOLSTER PLATE MOUNTING

This type of mounting, as shown in Fig. 1, is recommended for single units in either the Model C, D, MC, MD, HC or Model HD cushions, however, it is occasionally used for mounting multiple installations when the press bed is so designed that no other type of mounting can be used. The installation procedure is very simple, as it requires only the drilling and tapping of four holes in the bolster plate of the press. The mounting rods are provided with shoulders that automatically take care of the alignment of the cushion with reference to the bed of the press. When drilling and tapping bolster, extra care should be taken to measure that the holes are perpendicular to the bolster plate. As a general rule, those rods should not be out of parallel with the center line of the cushion by more than **.001 for each two inches of rod length** in order to reduce side stresses in the rods.



### PRESS BED MOUNTING

This type of mounting, as shown in Fig. 2, is used on single unit installations as well as on the larger, multiple installations. It is more desirable in most installations; because the bolster plate of the press can be removed at any time without disturbing the cushion unit. This feature is very desirable on presses where a variety of different types of tools are being used. The installation of a press bed mounting, however, requires greater care, because the mounting plate, as well as the pin pressure pad, must be aligned with the top of the press bed to avoid a tilting action on the cushion unit when in operation. **When the bed is tapped the same precautions as to out-of-parallel conditions should be applied as for bolster mounting.**



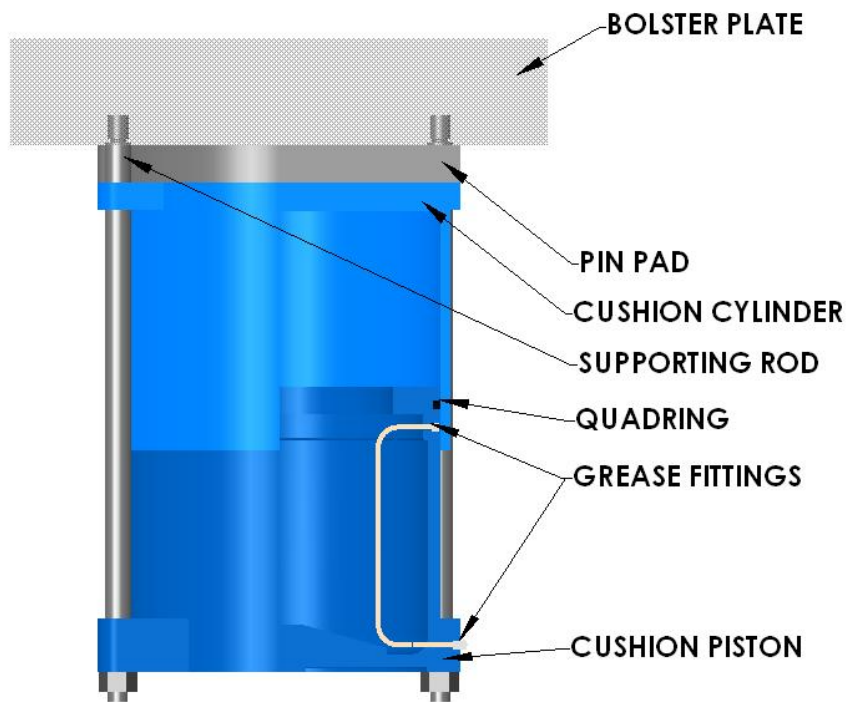

Fig. 1 Bolster Mounting

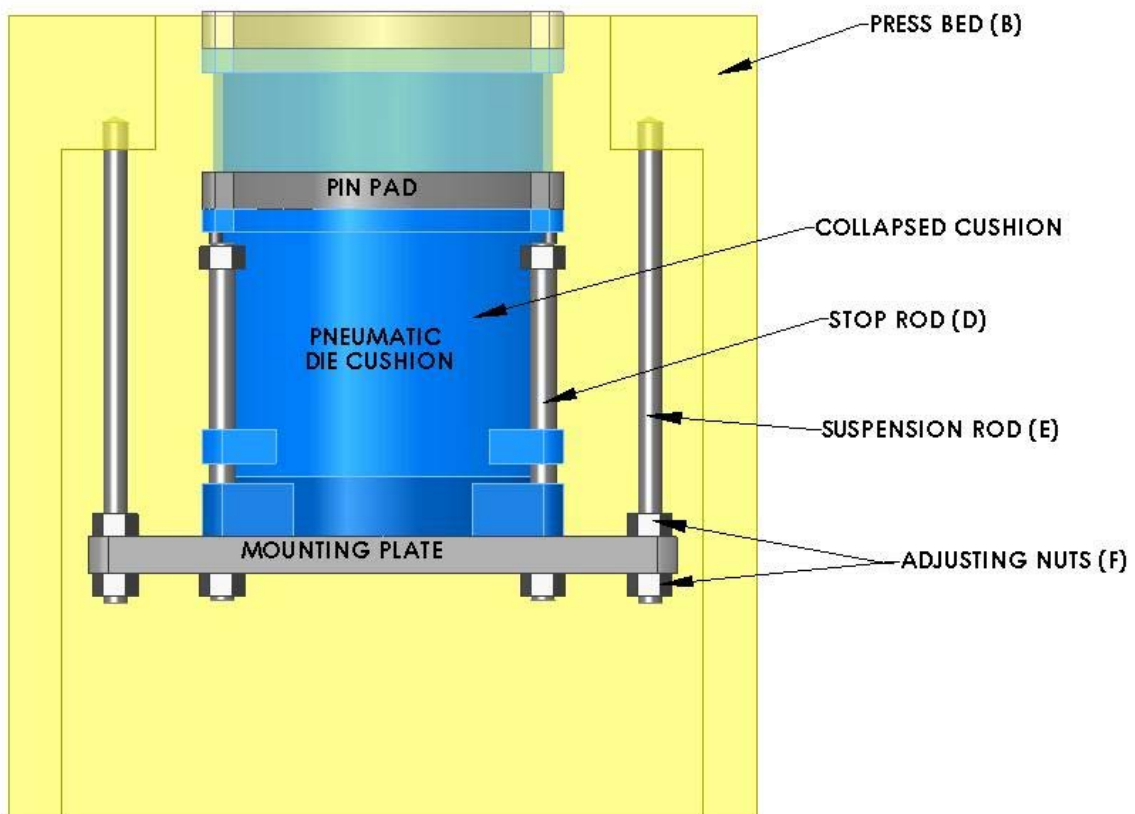

Fig. 2 Press Bed Mounting

## Installation Instructions

### Model HC Bolster Plate Mounting



**IMPORTANT!** Do not disassemble the cushion cylinder and piston when installing, because the packing will flare out and cause an air leak unless reassembled properly.

**NOTE:** All cushion installations are tested and inspected for air leaks before shipment.

The following is the recommended procedure for mounting a single unit Model "HC" to the bolster plate of a press:



(1) The die cushion should be mounted to the bolster plate so that it is centrally located with reference to the press bed opening. Scribe press bed opening on the under side of bolster plate, remove, and check both surfaces to make sure they are flat and parallel. **THIS IS IMPORTANT!** If surfaces are bowed or not parallel, have them machined and again scribe bed opening on bolster plate.

(2) Lay out holes according to "F" and "G", Fig. 4. The tolerance on these holes must be held to  $\pm 1/64$ " for proper alignment with mounting rods. Drill and tap holes according to dimensions "I" and "K", making sure holes are square to the under surface of the bolster plate (See page 3).

(3) Bolt bolster plate to bed in its normal position, and screw the ends of the mounting rods having the short length of thread into position. Make sure that the shoulders of these rods are securely tightened against the bolster plate.

(4) Position die cushion under rods, and raise so that rods pass through holes in base flange of cushion. Use temporary blocking if necessary to hold cushion until lock washers and nuts can be run on and tightened. (On HC-12 through HC-24 cushions, nuts should be pinned after assembled by cross-drilling, tapping, and inserting set screw).

(5) Install surge tank and booster pump per instructions on pages 15 and 24, respectively. Combination regulator and gauge (Page 13) can be substituted for booster pump if shop air pressure is adequate.

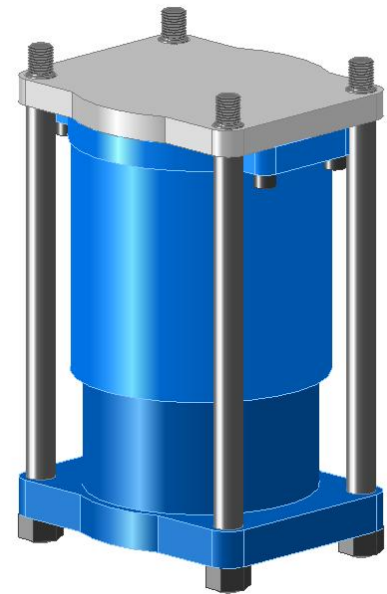

**Fig. 3 Model HC Die Cushion  
200 psi Max. Pressure**

(6) Lubricate unit until grease emerges from between piston and cylinder walls before initial operation. Note that the grease fitting located per chart below feeds the upper piston. The same procedure should be followed after **EVERY 8 HOURS** of operation. Use Dayton Die Cushions specially compounded lubricant (See page 30).



**IMPORTANT! READ CAREFULLY PRECAUTIONS FOR INSTALLATION AND OPERATION OF PNEUMATIC DIE CUSHIONS DESCRIBED ON PAGE 2.**

Cushion Size	Dimensions						
	C	D	E	F	G	I	K
HC-8	9 3/4	11 5/8	8 1/2	9 7/8	6 3/4	7/8-9	1
HC-10	11 3/4	13 11/16	10 1/4	11 11/16	8 1/4	18	1 1/4
HC-12	13 1/2	15 5/8	11 3/4	13 3/8	9 1/2	1 1/4-7	1 1/2
HC-14	16	17 5/8	13 3/8	15 1/8	10 7/8	1 1/4-7	1 5/8
HC-16	18	19 3/4	15	17	12 1/4	1 3/8-6	1 3/4
HC-18	20	22	16 3/4	19	13 3/4	1 1/2-6	1 7/8
HC-20	22 1/4	24 3/4	18 3/4	21 1/4	15 1/4	1 3/4-5	2
HC-22	24 1/4	26 1/2	20 1/4	22 3/4	16 3/4	1 3/4-5	2
HC-24	26 1/4	28 7/8	22 1/8	24 7/8	18 1/8	2-4 1/2	2 1/4

Cushion Size	Draw Length						Ring Holding Pressure @ 200 psi
	2	4	6	8	10	12	
	L	L	L	L	L	L	
HC-8	17 1/4	19 1/4	21 1/4				5.0
HC-10	19 1/2	21 1/2	23 1/2				7.8
HC-12		22	24				11.4
HC-14		23 3/4	25 3/4	29 3/4	33 3/4		15.4
HC-16		24 3/8	26 3/8	30 3/8	34 3/8		20.0
HC-18		26	28	32	36	40	25.4
HC-20		26 1/4	28 1/4	32 1/4	36 1/4	40 1/4	31.4
HC-22		28	30	34	38	42	38.0
HC-24		31 1/2	33 1/2	35 1/2	39 1/2	43 1/2	45.2

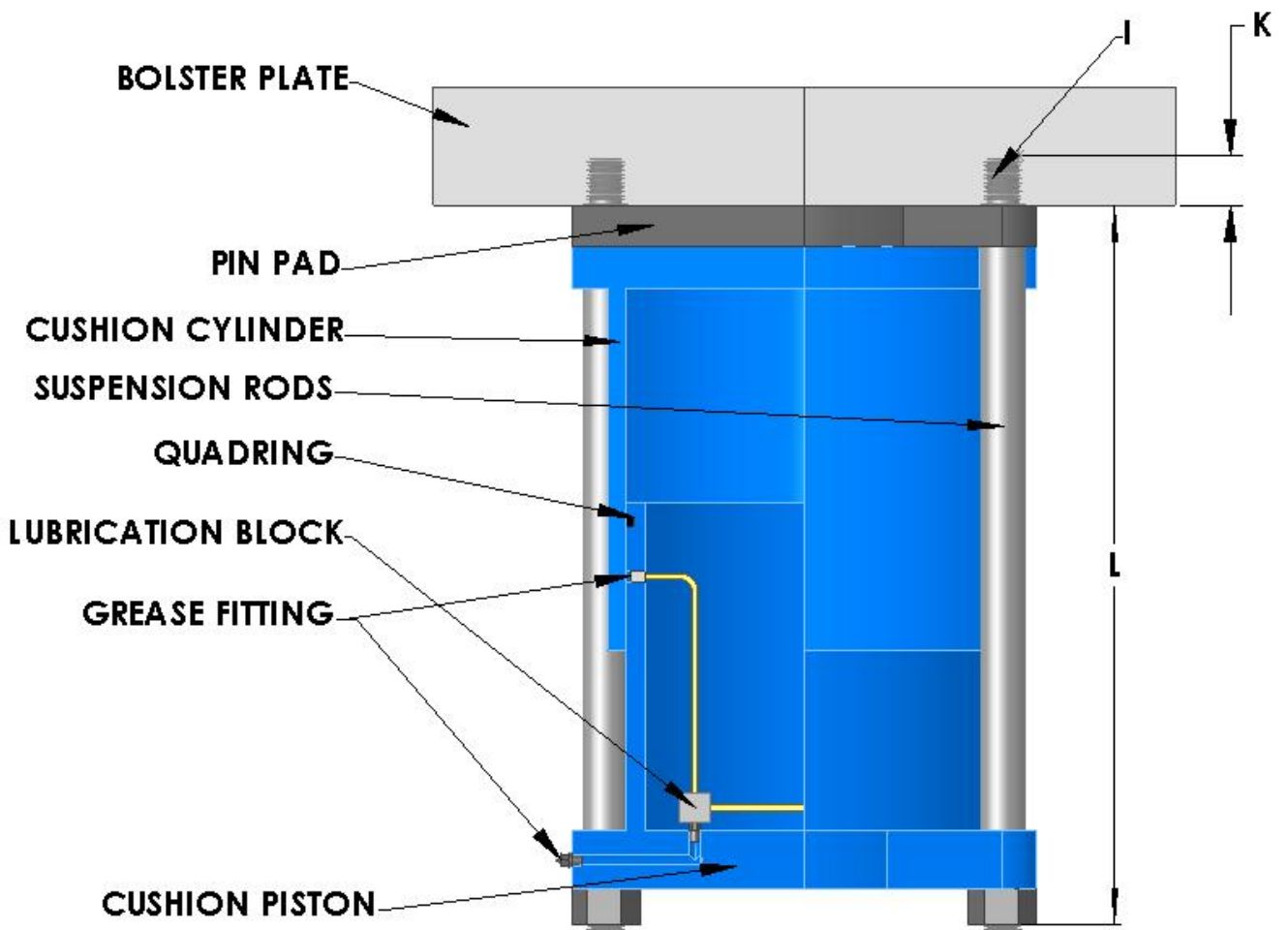
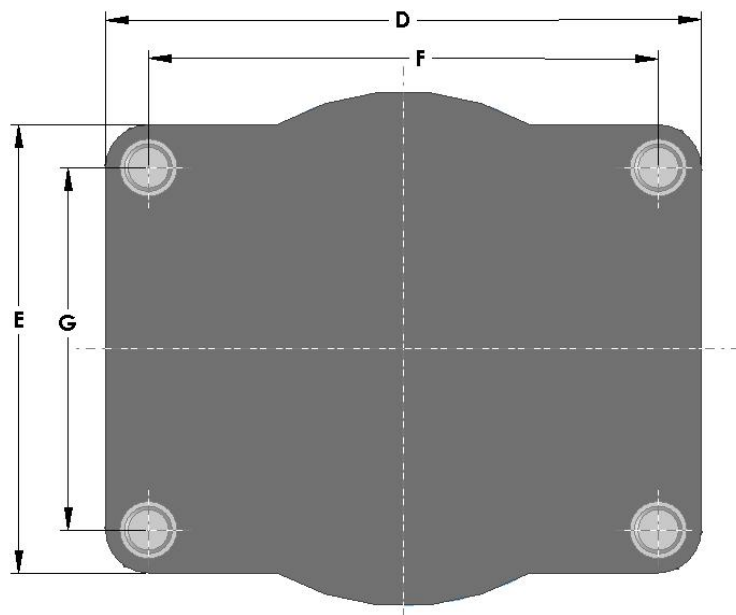

Fig. 4 Model HC Die Cushion – section and top view



## Installation Instructions

### Model HC Press Bed Mounting



**IMPORTANT!** Do not disassemble the cushion cylinder and piston when installing, because the packing will flare out and cause an air leak unless reassembled properly.

**NOTE:** All cushion installations are tested and inspected for air leaks before shipment.

The following is the recommended procedure for mounting a single unit Model "HC" to the press bed:



(1) Remove the bolster plate and check both surfaces carefully to make sure they are flat and parallel. **THIS IS IMPORTANT!** If surfaces are bowed or not parallel, have them machined and again scribe bed opening on bolster plate.

(2) Screw ends of rods having shortest thread into drilled and tapped holes provided in press bed. (See Page 3) If rods are to be mounted to bosses that are not tapped, be sure that nuts are provided on top and bottom of the bosses.

(3) Slide cushion into approximate location relative to press bed opening. (Note: If distance between rods is not great enough to allow cushion to slide between them, leave front rods out until cushion is positioned under press bed.)

(4) Run on upper mounting plate nuts as far as they will go; raise unit so mounting rods pass through holes provided in mounting plate, and run on lower mounting plate nuts.



(5) Model "HC" cushion can either be mounted so they stop against the bolster plate or against their own stop rod, according to customer's preference. If bolster stopping is desired, subtract 1/8" from dimension "H" and adjust mounting plate this distance below press bed surface. **BE SURE MOUNTING PLATE IS ADJUSTED PARALLEL TO PRESS BED.** Run upper nuts down tight against plate and pin both upper and lower nuts by cross-drilling, tapping, and inserting set screw.

(6) Follow steps 5 and 6, from pages 5 and 6, to hook-up installation for operation.



**IMPORTANT! READ CAREFULLY PRECAUTIONS FOR INSTALLATION AND OPERATION OF PNEUMATIC DIE CUSHIONS DESCRIBED ON PAGE 2.**

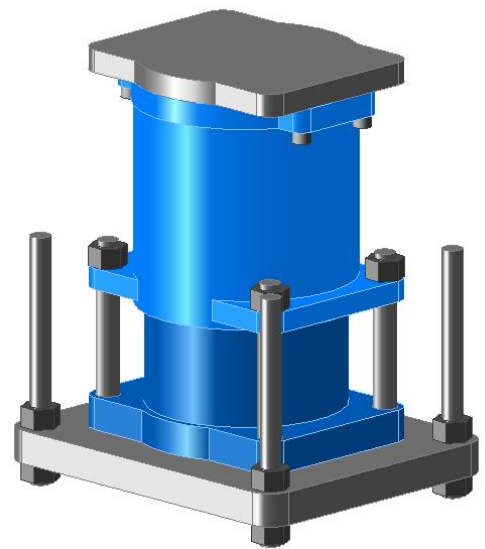

**Fig. 5 Model HC Die Cushion  
200 psi Max. Pressure**



Cushion Size	I	J	Draw Length						Ring Holding Pressure @ 200 psi
			2"	4"	6"	8"	10"	12"	
			H	H	H	H	H	H	
HC-8	7/8-9	1 1/4	17 1/4	19 1/4	21 1/4				5.0
HC-10	18	1 1/2	19 1/2	21 1/2	23 1/2				7.8
HC-12	1 1/4-7	1 1/2		22	24				11.4
HC-14	1 1/4-7	1 3/4		23 3/4	25 3/4	29 3/4	33 3/4		15.4
HC-16	1 3/8-6	2		24 3/8	26 3/8	30 3/8	34 3/8		20.0
HC-18	1 1/2-6	2		26	28	32	36	40	25.4
HC-20	1 3/4-5	2 3/4		26 1/4	28 1/4	32 1/4	36 1/4	40 1/4	31.4
HC-22	1 3/4-5	2 3/4		28	30	34	38	42	38.0
HC-24	2-4 1/2	3 1/4		31 1/2	33 1/2	35 1/2	39 1/2	43 1/2	45.2

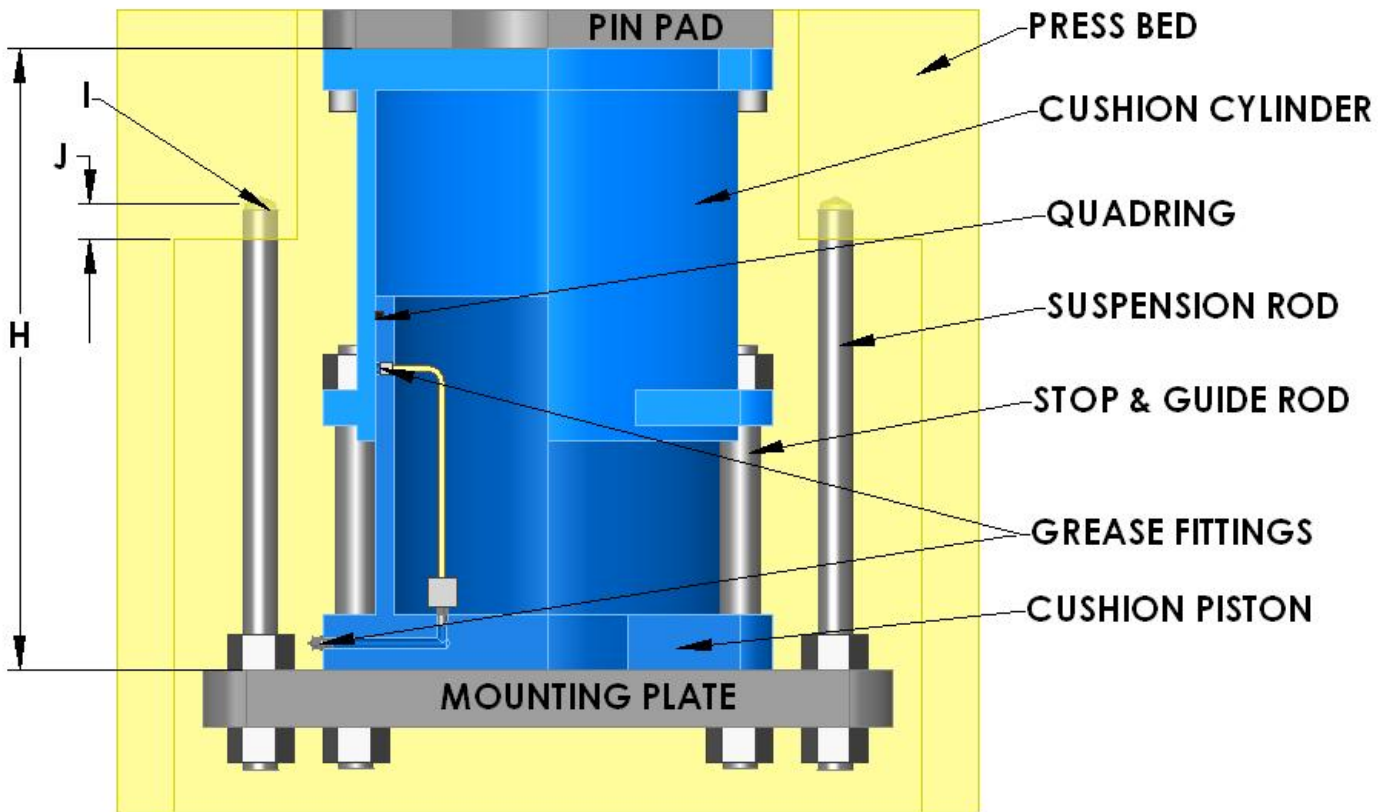

Fig. 6 Model HC Die Cushion – cross section view

## Instructions for Installing Multiple Cushions Installations (Models 2C, 3C, 2MC, etc.)

As a general rule, each multiple cushion installation requires special consideration in the design of the mounting structure. Consequently, it is usually necessary to create the installation drawings showing all the details as applied to each installation. These drawings are sent to the customer to be used when installing the cushion installation.



When installing a multiple cushion, it is very important that the bolster plate or any other surface against which the pin pad is to stop be flat and parallel. If the bolster or other surfaces are not flat and parallel, they should be machined so that the pin pad will have an accurate surface for a positive stop.



It is also important that the mounting plate or structure be aligned so that it is parallel with the top of the press bed and adjusted to the correct height. Since practically all multiple installations are mounted on a supporting structure, the instructions for press bed mounting on page 8 must be followed. The method for determining the height from the top of the press bed to the mounting plate or structure must be altered on some designs as follows:

### MODELS 2C, 3C, 2HC, 2MC, ETC.

When installing a 2C, 3C, etc., installation as shown in Fig. 7, the height from the top of the press bed to the mounting channels is determined by taking the overall height of the cushion plus the thickness of the pin pressure pad, minus 1/8". However, since spacers have been added between the bottom of the cushion unit and the top of the mounting channels, it is necessary to add the height of these spacers.

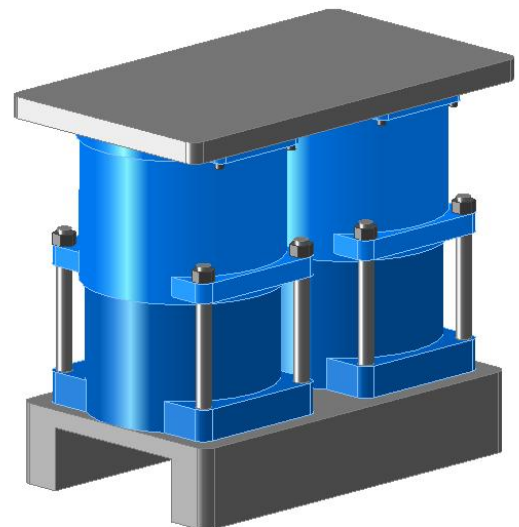

Fig. 7 2C12 PBM Die Cushions



Refer to page 15 for detailed instructions for installation of surge tank or tanks. It is important to note that surge piping for multiple installations with common pin pads must provide common interconnection between all cushions and surge tank or tanks. Regulating valve can be connected to any cushion in system (page 13) and air inlets in the remaining cushions can be plugged.

# PARTS LIST AND ACCESSORIES

## FOR

# PNEUMATIC DIE CUSHIONS

Should it be necessary to order repair parts, always give the **Cushion Model, Serial Number and Key Number** of the part. The serial number is stamped at the front of the lower left-hand flange of each cushion unit. The cushion model and maximum drawing depth is stamped on the same plate of each cushion unit. This information is very important, as it enables us to give prompt service, which we cannot do unless we know the exact cushion on which the new parts are to be used. It is seldom advisable to make your own repair parts, since the manufacturer has an accurate record of all parts for your pneumatic die cushion equipment and can furnish them directly from stock at a nominal charge.

In conclusion, remember there is no finer or better cushion built than the Dayton Die Cushions models. Remember, too, that no machine equipment, regardless of how well it is designed and built, will stand up for a long period under abuse, neglect or indifferent treatment. A careful study of the instructions in this book will insure you years of uninterrupted service.

## Cushion Surge Size

### Pipe Size Required from Cushion Unit to Surge Tank

### Model HC

Cushion Size	Number of Cushion Units					
	1	2	3	4	5	6
HC-6	1/2" NPT	3/4 " NPT	1 1/4" NPT	1 1/4" NPT	1 1/4" NPT	1 1/2" NPT
HC-8	1/2" NPT	3/4" NPT	1 1/4" NPT	1 1/4" NPT	1 1/4" NPT	1 1/2" NPT
HC-10	3/4 " NPT	1 1/4" NPT	1 1/2" NPT	2" NPT	2" NPT	2" NPT
HC-12	3/4" NPT	1 1/4" NPT	1 1/2" NPT	2" NPT	2" NPT	2" NPT
HC-14	1" NPT	1 1/2" NPT	2" NPT	2 1/2" NPT	2 1/2" NPT	3" NPT
HC-16	1 1/4" NPT	2" NPT	2 1/2" NPT	3" NPT	3" NPT	
HC-18	1 1/4" NPT	2" NPT	2 1/2" NPT	3" NPT	3" NPT	
HC-20	1 1/4" NPT	2" NPT	2 1/2" NPT	3" NPT	3" NPT	
HC-22	1 1/2" NPT	2 1/2" NPT	3" NPT			
HC-24	1 1/2 NPT	2 1/2" NPT	3" NPT			

## Installation Instructions and Parts List

### Combination Reducing Regulating Valve and Pressure Gauge

When installing a Dayton Die Cushions Combination Regulator and Pressure Gauge on a pneumatic die cushion installation, high pressure hoses should be used from the regulator to the cushion unit. A brass or steel pipe may be used; however, a high pressure hose is long-lived, and does absorb the shock of the press on the working equipment of the regulator as well as the pressure gauge.

The Combination Regulator and Gauge, which is furnished with a bracket, should be installed on the left-hand side of the press bed frame. It should be mounted approximately five or six feet from the floor within easy reach and view of the operator.

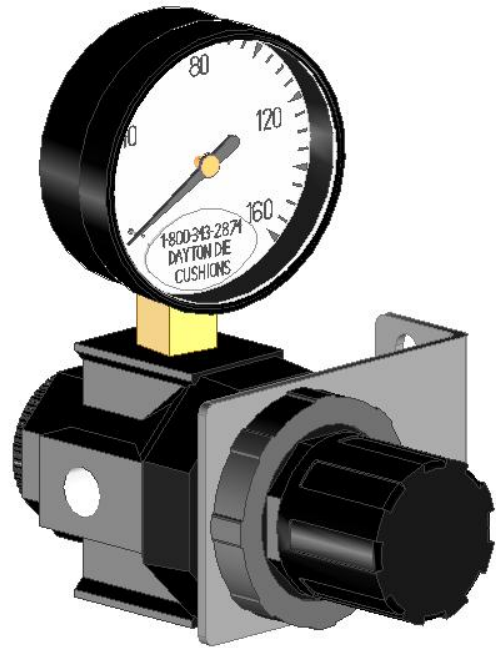

Fig. 8 Regulator and Gauge Assembly

It is very important that the vibration dampener be used when mounting the regulator in order to remove as much of the press shock from the regulator and gauge as possible. After the shop air line has been piped to within 2 or 2 1/2 feet of the pressure regulator, it is advisable to provide a globe shut-off valve on the end of the pipe so that the air pressure can be turned off when the cushion is not in use.

#### PRECAUTION



After the globe shut-off valve has been attached to the shop air line, be sure to blow out the shop air line to remove any foreign matter or dirt before connecting the short length of hose from the globe shut-off valve to the inlet side of the pressure regulator. If this precaution is not taken, there is a possibility a small piece of dirt will get under the seat of the regulator valve and it will not function properly. Also, note that the regulator openings are marked with an arrow to indicate direction of flow so that the air hoses can be connected to correct side for proper operation.

For high pressure cushions, model HC, regulator and gauge are mounted directly to the booster pump. The booster pump is connected to the cushion by means of the high pressure hose through the cross as shown in Fig. 20.

By recording the pressure required for a given job when it is first set up, it is an easy matter to reset the same die equipment at a later date by merely setting the pressure on the pressure gauge according to this reading.

### Pressure Gauge

The gauges supplied by Dayton Die Cushions have safety backs and 1/4-inch pipe thread on the inlet. For high pressure models, gauge is mounted directly to the booster pump. Also, each surge tank is supplied with the appropriate pressure gauge.

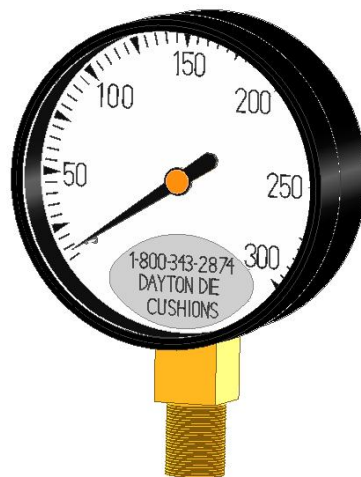

Fig. 9 Part Number 6114 High Pressure Gauge

Part Number	Dial Reading	Graduation Intervals	Diameter
6114	300 lbs.	5 lbs.	2 1/2 "

## Surge Tanks

On deep-drawing operations where the pin pressure pad is deflected to the maximum drawing capacity of the pneumatic die cushion, a surge tank reservoir is used so that the air compressed in the cushion cylinder will not build up to prohibitive pressure at the bottom of the work cycle of the press. The larger the surge tank used, the more constant the ring holding or pad pressure will be throughout the work cycle. Too small a surge tank or one connected with too small a pipe will cause a noticeable increased pressure during the work cycle of the pneumatic die cushion unit.

The size of the surge tank required depends on the combined piston area and the depth of the draw. **The volume of the tank plus the volume of the cushion when inflated should be six times the displacement of the cushion at maximum draw.** The pipe connection from the cushion to the surge tank should be sufficiently large to permit a free flow of air from the cushion to the surge tank. The pipe sizes given in the table below are the recommended sizes for cushion installations consisting of one to six cushion units.



Fig. 10 Surge Tank

All cushion units are drilled and tapped for the correct size surge line to handle the flow of air required. On multiple units a reducing bushing for the correct size is furnished to give the proper air flow for the entire installation. Each cushion installation should have its own surge tank, as the pressure in the cushion unit and the surge tank is practically the same at all times. This would make it impossible to use one surge tank for two cushion installations, particularly if they were being run under different air pressures.

It is advisable to install the surge tank as close to the cushion unit as possible to minimize the flow of air through surge lines. The surge tank itself may be installed in either a horizontal or vertical position. Each surge tank is provided with the required number of outlets for making either of the above installations.

All surge tanks furnished with pneumatic die cushions include pop safety valve, pressure gauge and drain cock. Tanks furnished with HC installations have pop safety valve set to relieve at 250 psi. All tanks are built to ASME and National Board of Registration Standards and are furnished with certified code tag.



## REPAIR PARTS FOR SURGE TANK AND ACCESSORIES

If it becomes necessary to order replacements parts for a surge tank and its accessories, order by part number according to the part list below.

Tank Number	Size	Volume	Outlet Port Size	Shipping Weight
6301	12 x 33	12 gal.	2" NPT	76 lbs.
6302	12 x 45	18 gal.	2" NPT	100 lbs.
6303	16 x 47	33 gal.	2 1/2" NPT	157 lbs.
6304	18 x 55	51 gal.	3" NPT	250 lbs.

Surge Tank Assembly	
Description	Part Number
	High Pressure Cushions
Surge Tank	See table above
Pop Safety Valve	6308
Pressure Gauge	6114
Surge Drain Cock	443

Please contact Dayton Die Cushions for bigger surge tank sizes.



## Lubrication

### Instructions and Parts List

All Dayton Pneumatic Die Cushions are thoroughly lubricated at the factory prior to shipment. It is advisable, however, to lubricate each fitting until grease emerges from between the piston and cylinder walls before cushion is put into operation. The same procedure should be followed after **every 8 hours** of operation. If the cushion is permitted to stand idle for a period of two or three weeks, the grease may dry out and as a result the packing will become hard and will possibly cause an air leak until it has softened up sufficiently. It may be necessary in some cases to inject grease into the lubrication system to soften up these packings so that they will retain their resiliency. A standard automotive pressure grease gun can be used on all lubricating fittings on Dayton Rogers pneumatic die cushions.

**DO NOT USE AN ORDINARY CUP GREASE, AS IT WILL NOT DISTRIBUTE ITSELF PROPERLY OVER INTERIOR SURFACES OF THE CYLINDER AND PISTON WALLS. LUBRICANT ESPECIALLY COMPOUNDED FOR DIE CUSHIONS IS AVAILABLE FROM DAYTON DIE CUSHION IN 35-LB. PAILS. SEE PAGES 73 AND 74 FOR DETAILS.**



**CAUTION!!** Failure to lubricate as instructed may result in permanent mechanical damage to internal working parts of die cushion. This may result in seizure of unit and the possibility of injury to operating personnel.

Models HC and HD Pneumatic Die Cushions (see Fig. 11) are lubricated through one fitting located on the piston base (either at the front or on the side). Lubricant is distributed automatically and evenly to all points of wear by means of lubrication distributor "F". If necessary, hose "C" can be removed by unscrewing grease fitting, "A".

## High Pressure Standard Lubrication Layout

	DESCRIPTION	PART NUMBER
A	Grease Fitting	15392
B	Cushion Cylinder	-
C	Nylon Tubing	15302
D	Cushion Piston	-
E	Grease Fitting	15392
F	Lub. Distributor	6620
G	Hex Nipple	14498
H	Lub. Fitting	210

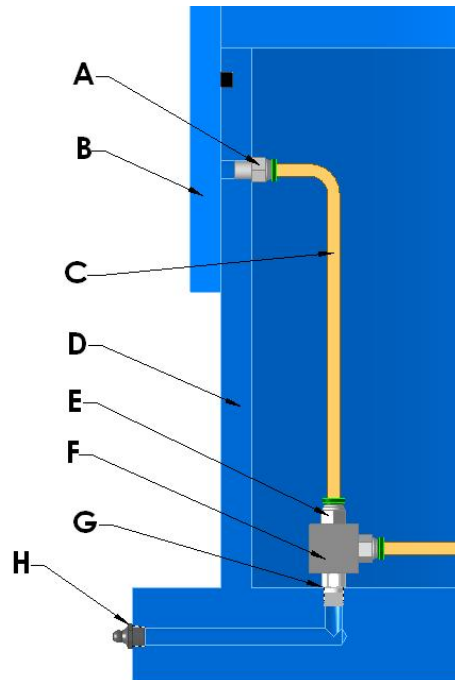

Fig. 11 Model HC Lubrication

## Centralized Lubrication

On some installations, particularly in the larger sizes, the press bed is so constructed that the grease fittings are not accessible. The lubrication of the cushion unit on installations of this type can be easily provided for by centralized lubrication. The centralized lubrication system consists of a header block (see Fig. 12) and 3/16" copper tubing that connects this header block directly to the die cushion unit. The header block is provided with as many grease fittings as there are in the complete cushion installation. These header blocks can be placed in any convenient location on the press and will permit easy and positive lubrication of all the necessary points on the cushion units. In addition to the copper tubing, all other fittings required for making the complete installation are furnished. This principle can be applied equally to both low and high pressure installations.

After centralized lubrication system has been installed, fill the lines with grease until it emerges from between the piston and cylinder walls. Check again after 8 hours operation to see how many shots are necessary to again cause grease to emerge. Thereafter lubricate this amount every 8 hours of operation.

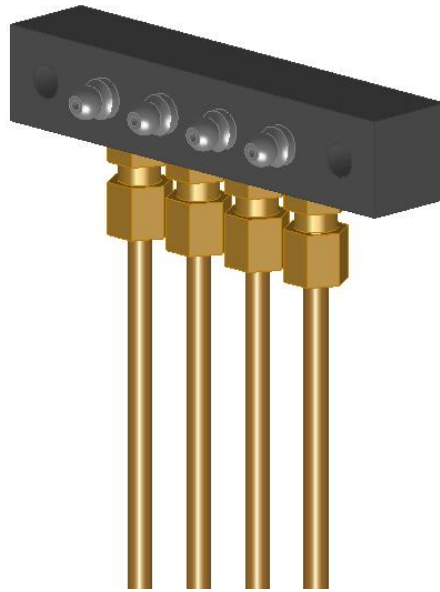

Fig. 12 Stage Header Block with Grease Lines Connected to it.

### Header Block Part List

	DESCRIPTION	PART NUMBER
A	Header Block	Refer to table below
B	Grease Fitting	625
C	Male Connector	2853
D	Compression Sleeve	867
E	Nut	6407
F	Copper Tubing	629

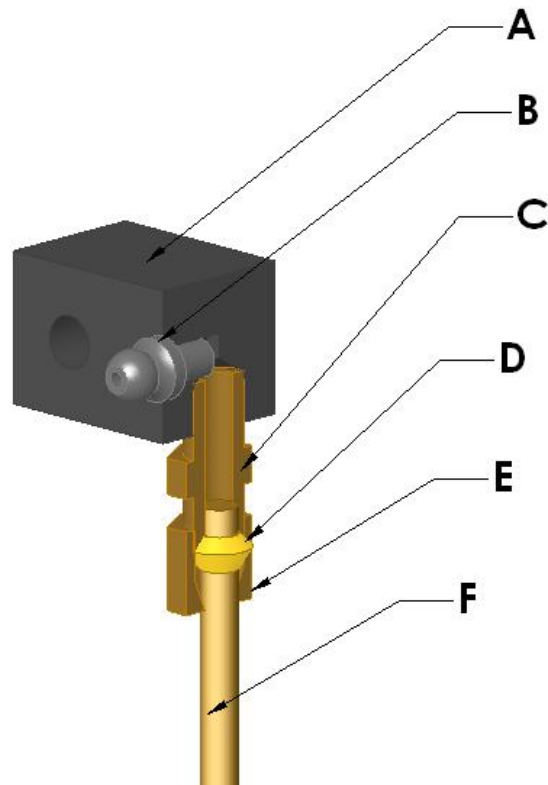

Fig. 13 Section view through the header block

Number of Header Block Stages	Part Number
2 Stages	6985
4 Stages	703
8 Stages	637

## Grease Fittings Part List for High Pressure Cushions

	DESCRIPTION	PART NUMBER
A	Copper Tubing	629
B	Nut	6407
C	Compression Sleeve	867
D	Male Connector	2853

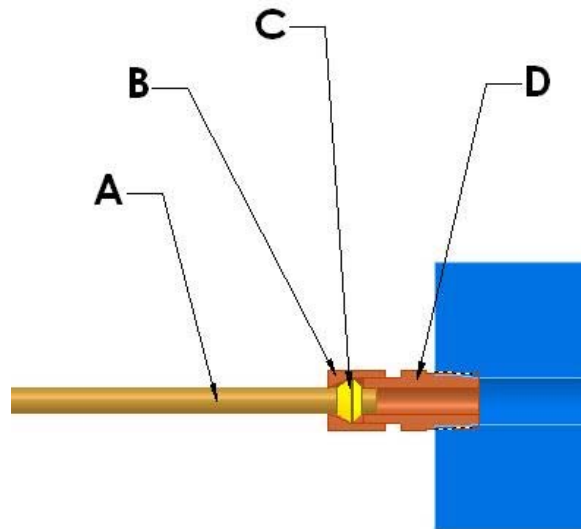

Fig. 14 Centralized lubrication fittings on the high pressure die cushion.

### Repair Parts

If it becomes necessary to order repair parts for the lubrication system on a pneumatic die cushion, please specify the quantity of items required, and the part number as shown in the part list tables above.

## Pneumatic Packings

**Dayton Die Cushions Packings** are of first quality material, thus assuring long wear and dependability under strenuous conditions. When ordering packings, please give model, size and serial number of cushion as well as part number of the packing.

There has been a **change in the type of packing** used on several models. Serial number higher than the one listed below for particular cushion model use quad packing instead of cup packing. Please refer to the tables below to check what type of packing your cushion uses.

Model HC Piston Packings				
	Piston Diameter	Cup Packing Part Number	Quad Ring Part Number	Cushion Serial Number *
HC-8	8"	169	8335	24997
HC-10	10"	490	8700	19626
HC-12	12"	492	10109	20115
HC-14	14"	179	9878	19343
HC-16	16"	168	10110	19253
HC-18	18"	650	10687	20056
HC-20	20"	970	10688	20009
HC-22	22"	1104	10689	19639
HC-24	24"	798	10690	19743
HC-30	30"	8650	10761	19974
HC-40	40"		10699	19600
HC-48	48"		10698	19560

\* Quad Ring Packings used after this Serial Number.



# Installation Instructions

## Cup Packings

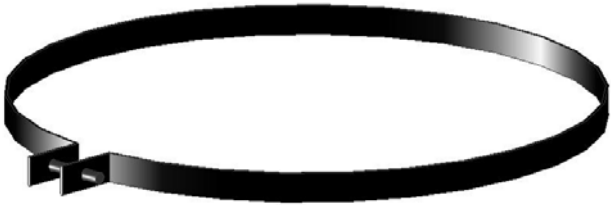

Fig. 15 Clamping band

**PRECAUTION:** When installing a cup packing, be careful not to damage or turn back the lip. This can be avoided by making a clamping band as shown in Fig. 15 from 16-gauge band iron, 1/2" to 1/8" wide. The ends of this band iron with two holes pierced to receive an ordinary stove bolt should be bent so that the circumference is a little less from bend to bend than the circumference of the piston of the pneumatic die cushion unit on which it is to be use.

	Description
A	Cushion Cylinder
B	Cup Packing
C	Clamping Band
D	1/4" Lockwasher (Part No. 438)
E	Cup Packing Ring
F	1/4"-20 x 3/4" Allen Cap Screw (Part No. 441)
G	Cushion Piston

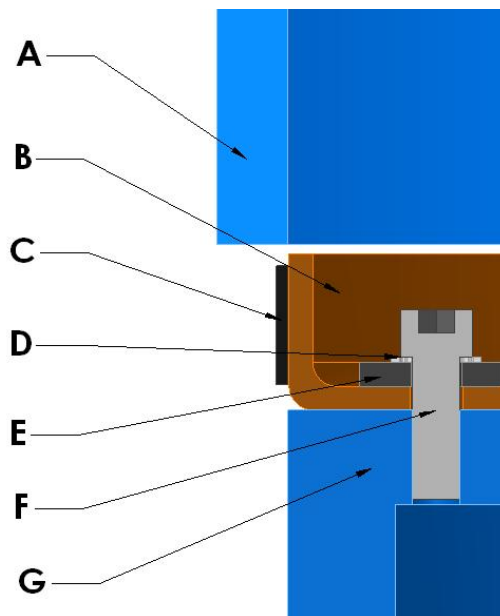

Fig. 16 Cup Packing Installation

## Installation Instructions

### Quad Packings

When installing quad packings it is advisable to grease the packing and groove thoroughly before cylinder is installed. Cylinder should be eased over packing to prevent shearing or gouging during installation.

**CAUTION:** It is advisable to check the 3/16" metal greasing tubes while the cushion unit is disassembled, because severe vibration may cause them to fracture at times. The lubrication instructions given on Page 17 will explain the procedure to follow in checking the lubrication system.

	Description
A	Cushion Cylinder
B	Quad Packing
C	Lubrication Tubing
D	Cushion Piston

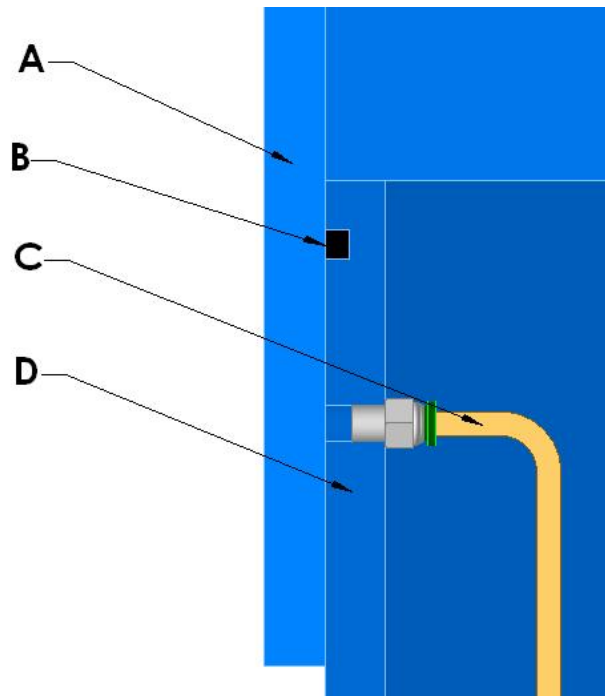

Fig. 17 Quad Ring Installation



# Installation Instructions

## Pneumatic Booster Pump

The booster pump is used with Dayton high pressure die cushions (models HC, HD and HMC). A piston rod is incorporated in the driving end. Two limit valves are mounted on the driving end head and a piston rod guide and limit valve actuators are attached to the piston rod. The limit valves control a 3 way control valve which in turn controls the booster. When the system is “powered up” the booster strokes, raising the fluid pressure in the output end. When it fully strokes, a limit valve is actuated, reversing the booster, resetting it. When it is fully reset, the other limit valve is actuated shifting the control valve for another power stroke. This cycle continues until the output pressure reaches the desired level. The booster then stalls out and holds that pressure until some of the air is used. The booster then resumes cycling until output air again reaches the desired pressure and the booster stalls out. This cycling will continue as long as the system is “powered up.”

During the stall mode there is no energy used, making the air powered booster an extremely efficient and quiet method of maintaining that high pressure. A hydraulic power unit, for instance, requires continuous energy input.

The input pressure is defined by the regulator mounted on the booster pump. The booster pump has 2.8 power factor. This means that if the input pressure is 70 psi, the maximum output pressure will be 200 psi (2.8 multiplied by 70 psi). However, the more effective way to achieve 200 psi system pressure is to use full input pressure (100 psi). After the desired system pressure (for example 200 psi) is achieved, the input pressure has to be backed off to the value that allows maintaining the required system pressure (in above mentioned example – 70 psi, which is equal to 200 psi divided by 2.8). This way shortens pump up time. In the table below, the input pressure values and corresponding average system pressures are presented.



**CAUTION! The maximum system pressure for models HC, HD and HMC die cushions is 200 psi! Do not exceed this value. There is the risk of accident, damage or death!**

Input pressure (regulator reading)	Resulting maximum system pressure
10 psi	30 psi
20 psi	55 psi
30 psi	85 psi
40 psi	110 psi
50 psi	140 psi
60 psi	170 psi
70 psi	200 psi



The pump can be mounted horizontally or vertically to the press frame or any other convenient place by bolting through four holes provided in the mounting structure. Select space large enough to accommodate pump as dimensioned in Fig. 18. If the pump is mounted on an uneven or curved surface, care should be taken not to bend pump. Booster pump should be connected to shop air line with standard pipe fittings (1/4" NPT) and to the cushion using high pressure hoses through the cross as shown in Fig. 20.

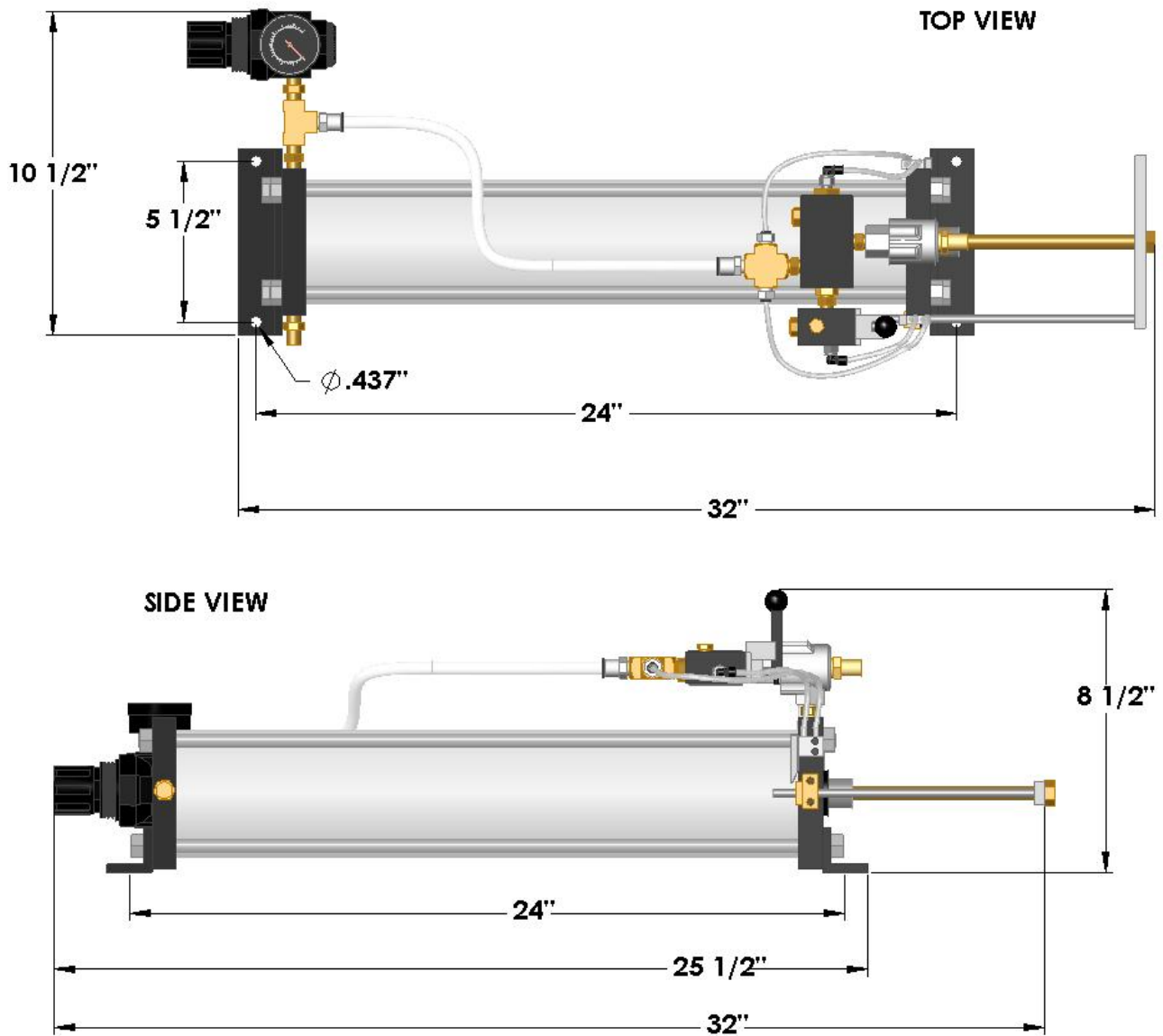

Fig. 18 Booster pump dimensions

## Booster Pump Parts List

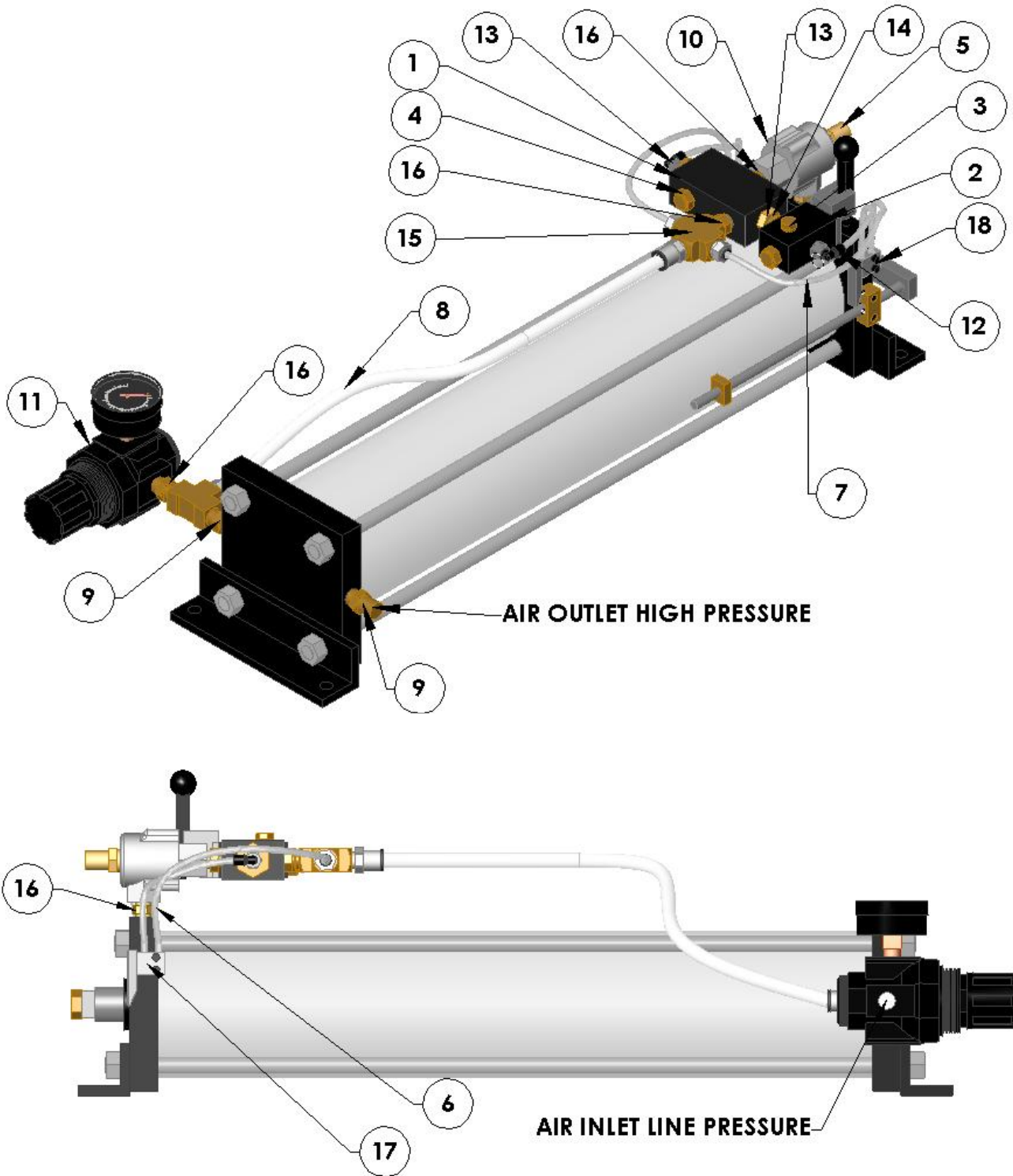

Fig. 19 Booster Pump (14799) part list

ITEM	QTY	PART NUMBER	DESCRIPTION
1	1	14DP-3	Fabco Valve
2	1	18HL-3	Valve
3	1	20311-1	Breather Vent F18
4	1	20311-2	Breather Vent F28
5	1	20311-3	Muffler P38
6	2	3109-04-11	Tube 5/32 X 1/8 NPT
7	2	3175-04-14	Tube 5/32 X 1/4 NPT
8	2	3175-60-14	Tube 3/8 X 1/4 NPT
9	2	CMMQ20B	Check Valve
10	1	EV250	Exhaust Valve
11	1	R27221-600	Regulator
12	4	1016	Fitting
13	2	106-0024	Brass Fitting
14	1	106-0051	Brass Fitting
15	1	106-0186	Brass Fitting
16	4	106-0189	Brass Fitting
17	1	MSV-2	Directional Control Valve
18	1	MSV-2	Directional Control Valve
19	1	BA/BP4-4SK	Packing Kit



## Model HC Parts List

**IMPORTANT:** When ordering repair parts, be sure to indicate cushion model and size, serial number and part number on purchase order to avoid errors.

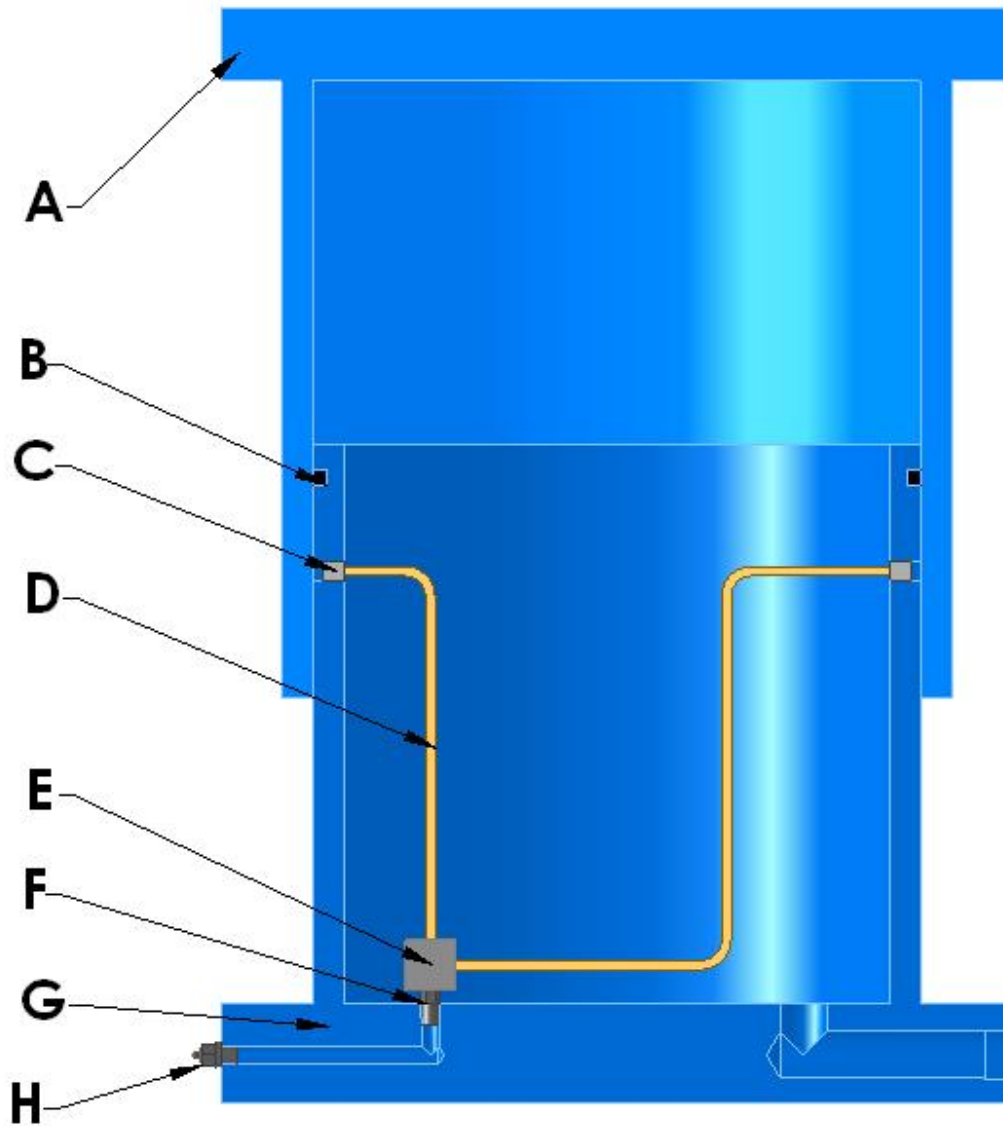

## Model HC Parts List

Description		Cushion Diameter and Part Number								
		8"	10"	12"	14"	16"	18"	20"	22"	24"
Cushion Cylinder <sup>(a)</sup>	A	6629	6671	6622	6595	6323	6281	6509	6506	6289
Quad Ring	B	8335	8700	10109	9878	10110	10687	10688	10689	10690
Grease Fitting	C	15392	15392	15392	15392	15392	15392	15392	15392	15392
Flex. Hose	D	10140	10140	10140	10140	10140	10140	10140	10140	10140
Pipe Tee	-	10965	10965	10965	-	-	-	-	-	-
Lub. Distributor	E	-	-	-	6620	6620	6620	6620	6620	6620
Hex Nipple	F	14498	14498	14498	14498	14498	14498	14498	14498	14498
Cushion Piston <sup>(a)</sup>	G	6630	6672	6623	6596	6324	6282	6581	6507	6290
Lubrication Fitting	H	210	210	210	210	210	210	210	210	210

(a) When ordering cylinders and cushion pistons, order according to cushion model and serial number (Serial Number is located at the front, lower flange of the cushion unit)



# Tonnage and Ring Holding Force Necessary For Drawing Shells\*

## A. Tonnage for Drawing Shells

In general, the tonnage necessary to draw a shell of round or rectangular shape is a function of the area of metal in the wall (i.e. = mean perimeter and metal thickness). This is true because at any given time, the force necessary to deform the metal equals the area of metal being deformed multiplied by the yield strength of the material. (In calculating these forces tensile strength is used, since this will either draw the part, push out the bottom or tear the walls). This is generally true for parts having odd shapes, although there are other factors involved which complicate the operation.

### 1. ROUND SHELLS

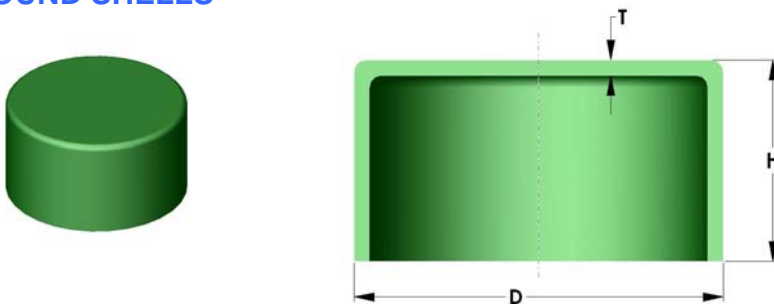

$$\text{TONNAGE} = \frac{\pi \cdot D \cdot T \cdot \text{TENSILE STRENGTH}}{2000}$$

### 2. RECTANGULAR SHELLS

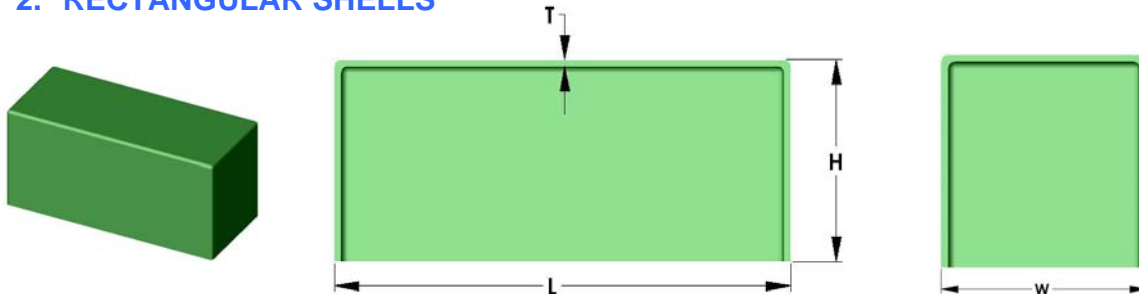

$$\text{TONNAGE} = \frac{2(L + W) \cdot T \cdot \text{TENSILE STRENGTH}}{2000}$$

\*This information is general and should be treated as such. Specific forces must be determined for each job.

Mechanical punch presses are designed to deliver their maximum tonnage near the bottom of the stroke. Since drawing work actually starts before bottom, the full tonnage will not be available. The above results, therefore, should be multiplied by .G. factor (Chart 1) when this type press is used.

H	"G"	H	"G"	H	"G"	H	"G"
1/2	1	3	1.75	10	3	18	4.0
1	1	4	2	12	3.25	20	4.25
1 1/2	1.5	6	2.5	14	3.5	22	4.5
2	1.5	8	2.75	16	3.75	24	4.75

FACTOR "G" CHART 1

### B. Ring Holding Pressure or Force

The primary function of the draw ring is to hold the blank while it is being formed to prevent wrinkles. Since the resistance to wrinkling becomes greater as the metal thickness increases, the necessary R.H.F. decreases. Experience indicates that a close approximation to the R.H.P. can be obtained by multiplying the tonnage required to draw the shell by "J" factor (Chart 2). **Note: Disregard "G" factor for this calculation.**

FACTOR "J" CHART 2

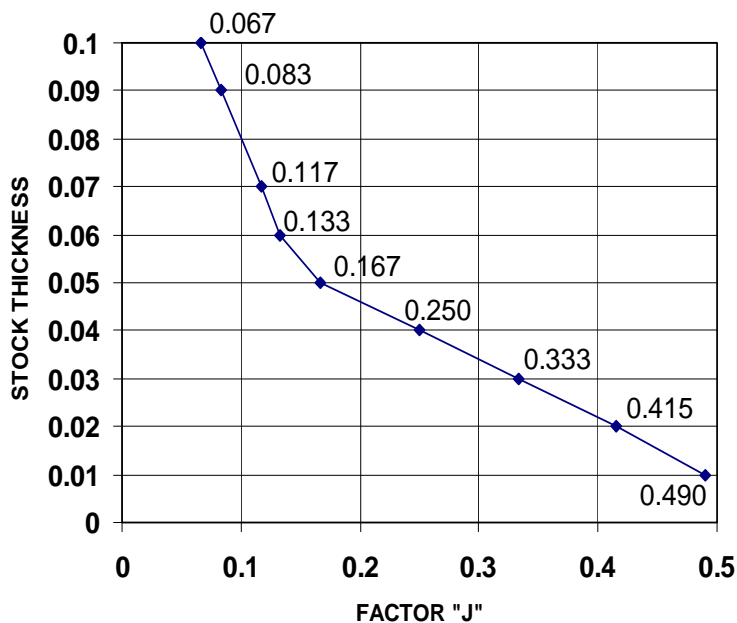



### C. Press Tonnage

Size of press necessary to draw shell in question is as follows:

**MINIMUM PRESS TONNAGE = SHELL TONNAGE PLUS CUSHION TONNAGE (R.H.P.)**

### D. Example

Determine the size of mechanical press required to draw the shell pictured.

$$DRAW\ TONNAGE = \frac{\pi \cdot (2.50 - 0.06) \cdot 0.06 \cdot 55,000}{2000} = 12.7\ T \cdot 1.5\ ("G") = 19.0\ T$$

$$CUSHION\ TONNAGE = 12.7\ T \cdot 0.133\ ("J") = 1.7\ T$$

$$MINIMUM\ MECHANICAL\ PRESS\ TONNAGE = 19.0\ T + 1.7\ T = 20.7\ T$$

$$MINIMUM\ HYDRAULIC\ PRESS\ TONNAGE = 12.7\ T + 1.7\ T = 14.4\ T$$

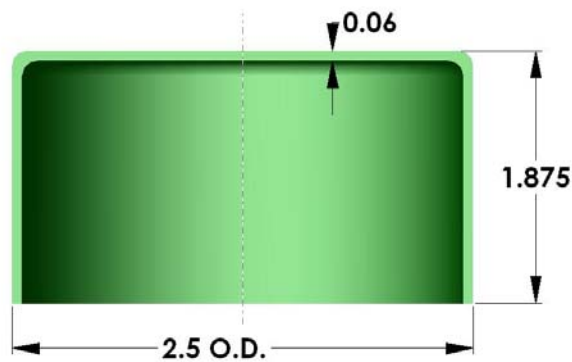

## Tonnage Capacities on Presses

Capacity of Crankshafts at the Bottom of the Stroke					
Crank Shaft Dia. (inches)	Tons		Crank Shaft Dia. (inches)	Tons	
	Single Crank Press	Double Crank Press		Single Crank Press	Double Crank Press
1 3/8	6	...	6 1/2	150	150
1 1/2	7.5	...	7	180	180
1 5/8	9	...	7 1/2	215	215
1 3/4	10.5	...	8	255	255
1 7/8	12	...	9	345	345
2	14	...	10	440	450
2 1/8	16	...	11	545	650
2 1/4	18	...	12	665	900
2 1/2	22	22	13	790	1150
2 3/4	26.5	26.5	14	920	1400
3	31.5	31.5	15	1060	1700
3 1/4	37	37	16	...	2000
3 1/2	43	43	16 1/2	1300	...
4	56	56	17	...	2300
4 1/2	71	71	18	1560	2700
5	88	88	20	1950	...
5 1/2	106	106	22	2380	...
6	126	126	24	2860	...

The tonnage figures do not apply to end wheel type of presses with overhanging crank-pin.

It is customary to equip the average punch press with a pneumatic die cushion that will develop a drawing holding pressure equal to one-sixth the total press tonnage. However, present practice indicates a trend toward cushion ratios approaching one fifth of the press tonnage. On the average inclinable press, it is usually desirable to use an HC or MC type installation because the press bed opening is not large enough to permit installation of a C or D cushion that will develop enough ring holding pressure.

To figure the draw-ring holding pressure produced by a pneumatic die cushion, multiply the area of the piston or pistons in square inches by the air pressure applied. For example, if an 8" diameter cushion is used which has a piston area of 50 square inches and the working pressure supplied from the shop air line is 50 pounds per square inch, the ring holding pressure developed would be 50 times 50 or 2,500 pounds pressure. In other words, the maximum ring holding pressure developed by an 8" diameter cushion on a 50-pound maximum shop air line would be 1 1/4 tons.

## Die Cushion Lubricant for All Pneumatic Die Cushions



As a result of careful tests and experimental research work, this die cushion lubricant is especially compounded for all pneumatic the cushions. It assures maximum packing life and also provides proper lubricant between the cylinder and piston surfaces of the die cushion units and all other working parts.

**It is available from stock in 35-pound pails direct from the Dayton Die Cushions.**



## HIGH PRESSURE CUSHION PIPING LAYOUT (FIG. 20)

No.	Description
1	Surge Tank
2	Drain Cock
3	Pop Safety Valve
4	Gauge
5	Red. Bushing
6	Pipe Nipple *
7	Elbow *
8	Elbow *
9	Union *
10	Drain Cock
11	Red. Bushing
12	Cross
13	Union *
14	Pipe *
15	Elbow *
16	Hose
17	Air Filter *
18	Water Trap & Drain *
19	Tee *
20	Shut-Off Valve *
21	Booster Pump
22	Pipe *

\* Indicates furnished by customer

Note: Drain Cock at lowest point in system

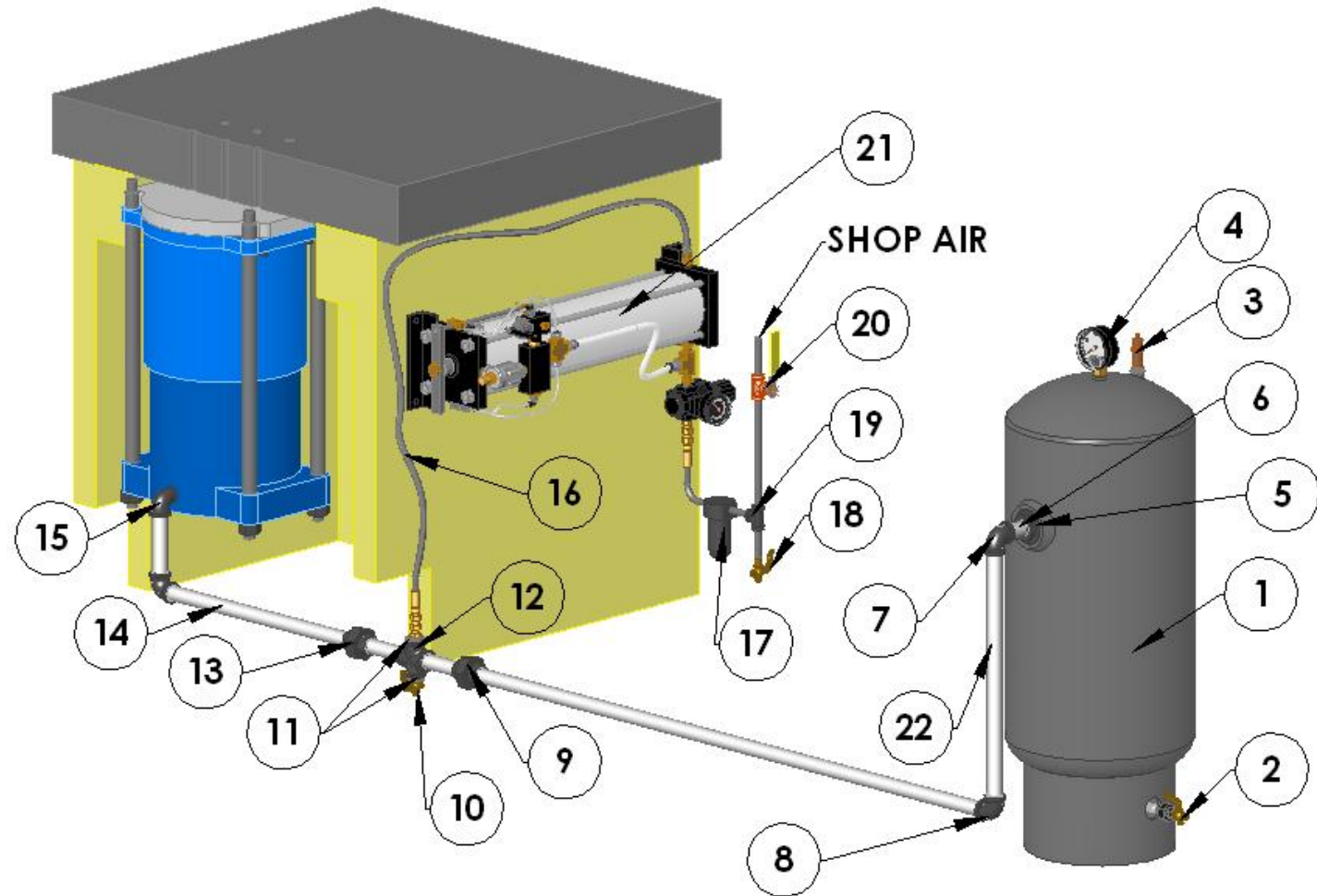

## MULTIPLE HIGH PRESSURE CUSHIONS PIPING LAYOUT (FIG. 21)

No.	Description
1	Surge Tank
2	Drain Cock
3	Pop Safety Valve
4	Gauge
5	Red. Bushing
6	Pipe Nipple *
7	Elbow *
8	Elbow *
9	Union *
10	Drain Cock
11	Red. Bushing
12	Cross
13	Union *
14	Tee
15	Elbow *
16	Hose
17	Air Filter *
18	Water Trap & Drain *
19	Tee *
20	Shut-Off Valve *
21	Booster Pump
22	Pipe *

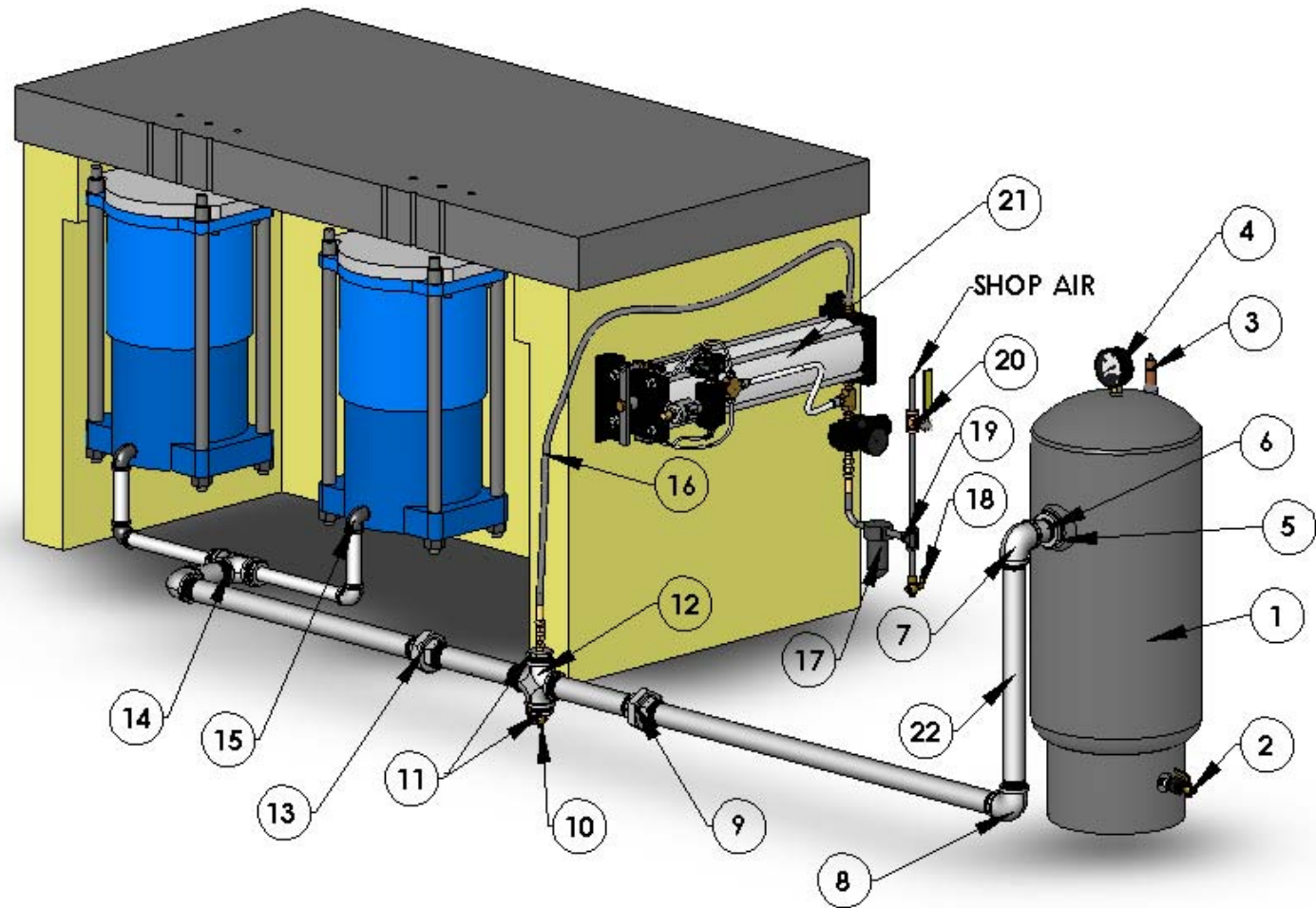

\* Indicates furnished by customer

Note: Drain Cock at lowest point in system. See page 12 for correct surge line size. Surge line becomes larger once it is common between cushions. Plumbing needs to be symmetric for each of the cushions.